

Addressed module 5 inputs

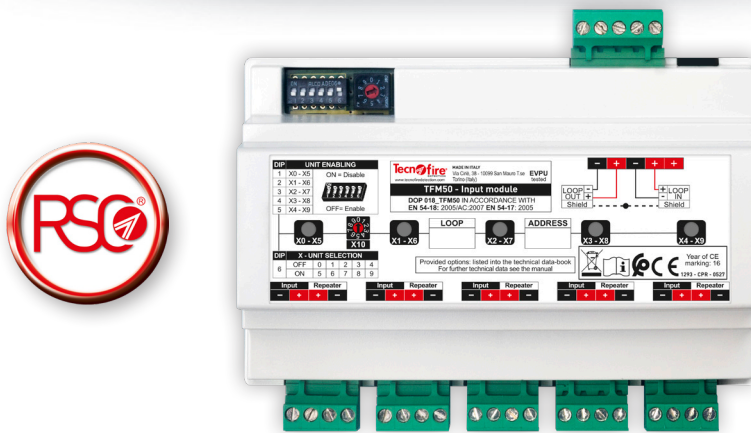

TFM50-HP addressable module equipped with 5 inputs, individually identified by the system. Inputs connection in Alarm or Fault mode. Programmable operating criteria. 5 outputs for optical repeaters. 5 input status indicator LED. Module operating statuses can be used as operands in formulas. RSC® management: programming, remote management and control. Loop connection. Dual short-circuit isolator. Fixing on a surface or on a DIN bar. Protection rating IP4x. ABS casing. White colour. Dimensions (L x H x D) 144 x 92 x 71,5mm.

TFM50-LP addressable module with the same electrical functional characteristics of the TFM50-HP model, but with installation in reduced height casing. Dimensions (L x H x D) 144 x 92 x 38,5mm. EN 54-18:2005/AC:2007 - EN 54-17:2005. Certificato di omologazione: 1293-CPR-0527.

| MODEL | | | | | | | | |
|----------|------------|--|--|--|--|--|--|--|
| Name | Item no. | | | | | | | |
| TFM50-HP | TF4TFM50HP | | | | | | | |
| TFM50-LP | TF4TFM50LP | | | | | | | |

OBLIGATIONS AND WARNINGS

The TFM50 module can only be used if connected to a detection loop of a Tecnofire Analog Addressable control panel. During the design and installation phases, it is mandatory to observe and apply the regulations in force.

LOGICAL UNITS

The module consists of five physical/logical units (five inputs). Inputs can be excluded using DIP switches 1 to 5. The inputs take an address based on the main address assigned to the module. The number of available inputs and the occupation of their respective addresses vary according to any exclusions made. Addresses relating to excluded inputs remain free and can be used to address other modules in the system.

ADDRESSING

The physical identification addresses for the module's inputs are programmed using the decimal rotary switch and the position of DIP 6, as shown in the table.

Rotary Switch: Used to program the tens digit (X10) for the addresses assigned to the five inputs.

DIP 6: Used to program the high or low sequence of the addresses assigned to the inputs:

- With DIP 6 OFF, the low sequence from X0 to X4 is programmed.
- With DIP 6 ON, the high sequence from X5 to X9 is programmed.

The numerical range for module addresses is from 01 to 99.

LINE SEPARATOR

The module is equipped with a line separator featuring a dual isolator. In the event of a short circuit on the Loop line, the separator triggers to isolate the section of the line affected by the fault, ensuring the correct operation of the devices connected upstream and downstream. The intervention of the line separator preserves the regular functioning of the loop and generates a "Separator open" fault signal.

| | | DIP 6 position | Inputs / Addresses | | | | |
|---|-----|----------------|--------------------|----|----|----|----|
| | | | A | B | C | D | E |
| | 0 | OFF | 00* | 01 | 02 | 03 | 04 |
| | | ON | 05 | 06 | 07 | 08 | 09 |
| | 1 | OFF | 10 | 11 | 12 | 13 | 14 |
| | | ON | 15 | 16 | 17 | 18 | 19 |
| | 2 | OFF | 20 | 21 | 22 | 23 | 24 |
| | | ON | 25 | 26 | 27 | 28 | 29 |
| | 3 | OFF | 30 | 31 | 32 | 33 | 34 |
| | | ON | 35 | 36 | 37 | 38 | 39 |
| | 4 | OFF | 40 | 41 | 42 | 43 | 44 |
| | | ON | 45 | 46 | 47 | 48 | 49 |
| 5 | OFF | 50 | 51 | 52 | 53 | 54 | |
| | ON | 55 | 56 | 57 | 58 | 59 | |
| 6 | OFF | 60 | 61 | 62 | 63 | 64 | |
| | ON | 65 | 66 | 67 | 68 | 69 | |
| 7 | OFF | 70 | 71 | 72 | 73 | 74 | |
| | ON | 75 | 76 | 77 | 78 | 79 | |
| 8 | OFF | 80 | 81 | 82 | 83 | 84 | |
| | ON | 85 | 86 | 87 | 88 | 89 | |
| 9 | OFF | 90 | 91 | 92 | 93 | 94 | |
| | ON | 95 | 96 | 97 | 98 | 99 | |

* Address 00 is not managed



TECNO - INPUT MODULE PROGRAMMING

One of the eight available operating criteria can be associated with the TECNO-input module. The status of the inputs is displayed by the IN1 and IN2 monitor LEDs.

The two inputs are equipped with their respective outputs for managing remote optical indicators.

| CONTACT TYPE | |
|----------------|------------------------|
| ACTIVATE ALARM | EOL RESISTOR (FAILURE) |

| FUNCTIONAL CRITERIA | |
|-----------------------------------|--|
| Generate alarm | The activation of the input triggers an alarm |
| None | The activation of the input does not trigger direct actions; this criterion can be used within a logic formula |
| Generate acknowledgment | Non-EN 54 function - The activation of the input silences the current event |
| Generate reset | Non-EN 54 function - The activation of the input triggers a system reset |
| Stop/reset sirens | Non-EN 54 function - The activation of the input silences and restores the system's siren outputs |
| Feedback | The activation of the input is used to verify the execution of a command (Feedback) |
| Stop/reset sirens - status | Non-EN 54 function - The activation of the input follows the status of the Silence/Restore Sirens command |
| Exd./reset output - status | Non-EN 54 function - The activation of the input follows the status of the Exclude/Restore Outputs command |

TEST FUNCTIONS

Tecnofire control panels manage a series of specialized Test and diagnostic functions for each type of module.

The functions available for the TECNO-input module are indicated in the following tables.

| TECNO-input MODULE DIAGNOSTIC FUNCTIONS | |
|---|--|
| Identification | Turns on the device LED for identification |
| Self declaration | Self declaration of the module type |
| HW release | Self declaration of the hardware version |
| FW release | Self declaration of the firmware version |
| Level reading | Detection of operating electrical values |
| Resistance monitor | Line termination resistance measurement monitor |
| Statistic | Statistic/functional values related to communication |

31/01/2024 Access level 3 08:00:00

Menu Test module 3 Loop 1

Identification TECNO - input

Self declaration 0.1

HW release 1.14

FW release

Level reading

Resistance monitor

Statistic

| | |
|--------------------|-----------------------|
| Consumption | Strings sent |
| Power supply level | Errors |
| Zero level | Percentage of success |
| Consumption level | Percentage of errors |
| Loop resistance | Latency |

31/01/2024 Access level 3 08:00:00

Monitor Loop 1 Module 3

Reading: 47500 ohm Time: 129 sec.

Minimum: 47500 ohm Maximum: 47500 ohm

OVERVIEW

DIP 1...5: Input exclusion
DIP 6: Address sequence selection

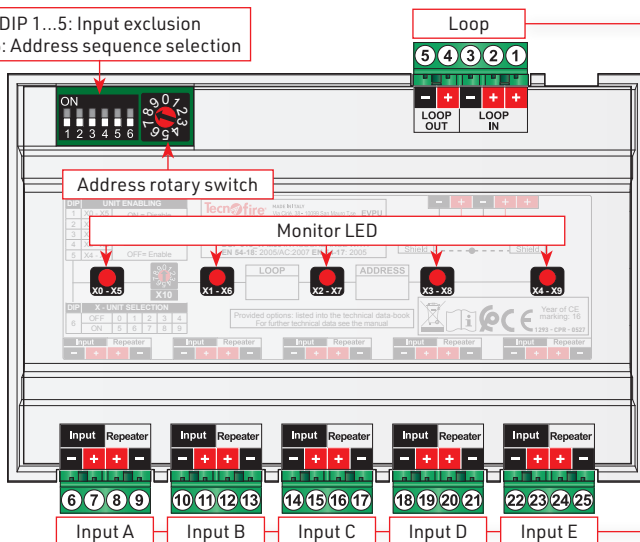

- | | |
|---|-----------------------------|
| 1 | Input Loop + (non-isolated) |
| 2 | Loop input + |
| 3 | Loop input - |
| 4 | Loop output + |
| 5 | Loop output - |

| INPUTS MONITOR LEDs | |
|---------------------|-------------------------|
| Loop Monitor | Flashes if not disabled |
| Signaling | LED ON |

| | | | | | |
|---|----|----|----|----|-------------------------------------|
| 6 | 10 | 14 | 18 | 22 | Input |
| 7 | 11 | 15 | 19 | 23 | Positive input reference |
| 8 | 12 | 16 | 20 | 24 | Optical repeater output |
| 9 | 13 | 17 | 21 | 25 | Optical repeater reference negative |

INPUT EXCLUSION

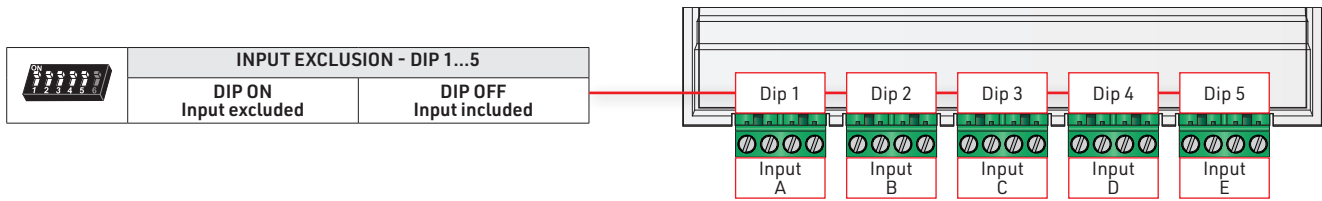

CONNECTION TO THE LOOP

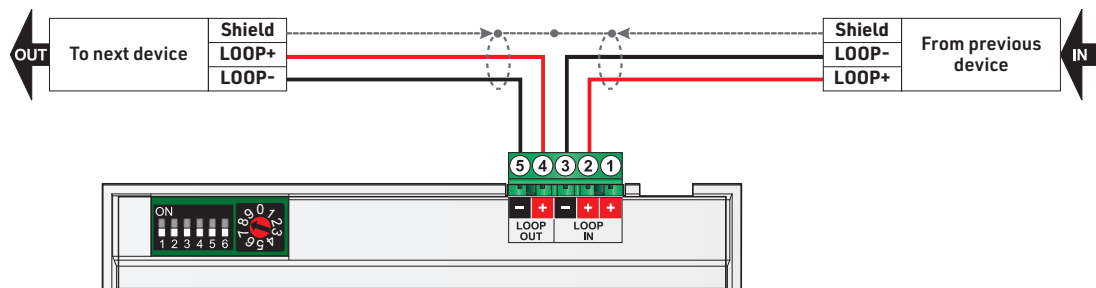

INPUTS CONNECTION



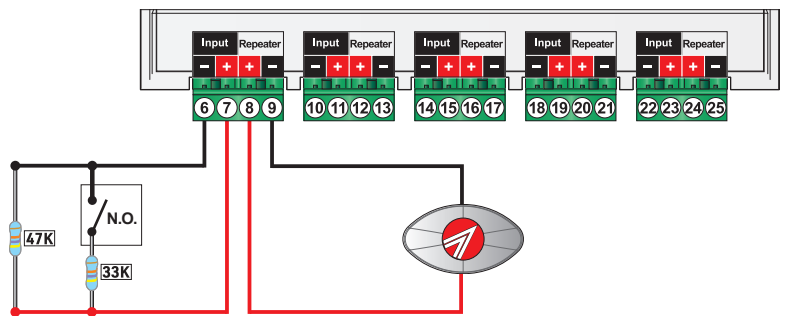

| INPUT FUNCTION / OPERATING STATES | |
|-----------------------------------|-------------------------------|
| ACTIVATE ALARM | EOL RESISTOR (FAILURE) |
| Fault (short circuit) | Fault (short circuit) |
| Alarm | General fault |
| Standby | Standby |
| Fault (open circuit) | Fault (open circuit) |

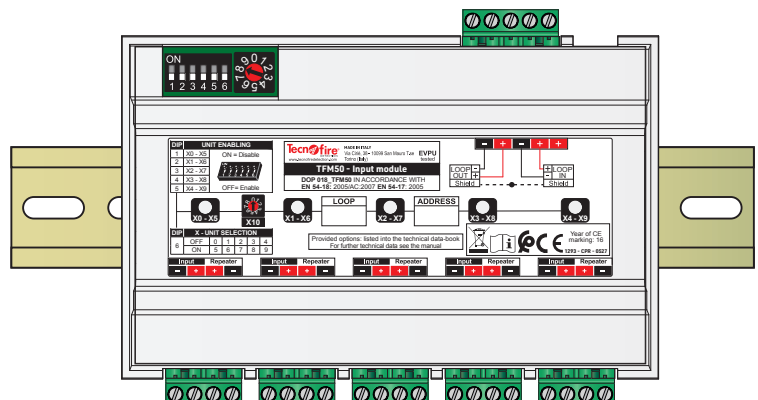
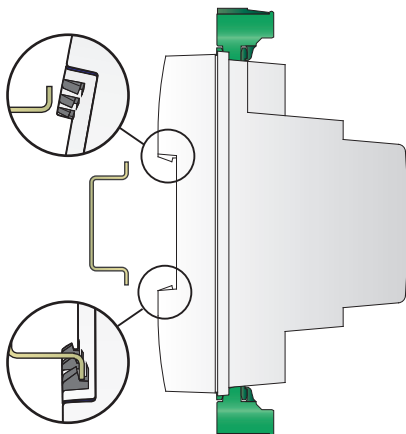

DIN RAIL MOUNTING



Accessories

| | | | |
|---|--|--|--|
|  | TFRIP-R Optical repeater, red LED. 360° visibility. Surface mounting. ABS casing. IP22. White colour. Dimensions (L x H x D) 78 x 45 x 25mm. Item no. TF3TFRIPR |  | TFRIP-V Optical repeater, green LED. 360° visibility Surface mounting. ABS casing. IP22. White colour. Dimensions (L x H x D) 78 x 45 x 25mm. Item no. TF3TFRIPV |
|  | TFRIP-R INC Optical repeater, red LED. 360° visibility. Flush mounting. Protection rating IP67. Item no. TF3TFRIPRINC |  | TFRIP-G Optical repeater, yellow LED. 360° visibility Surface mounting. ABS casing. IP22. White colour. Dimensions (L x H x D) 78 x 45 x 25mm. Item no. TF3TFRIPG |

Technical and functional specifications

| | | | | | |
|--|------------------------------------|---|---|--------------------------------------|--|
| General information | Addressed module 5 inputs | TFM50 | Physical specifications | Operating temperature | -15°C...+70°C |
| | Available logical units | 5 | | Relative humidity (non-condensing) | 10%...93% |
| Programmable functions | Polling frequency | Programmable | Protection class | IP4x (EN 60529) | |
| | Polling signaling LED | Excludable | Casing | ABS | |
| | Functional criteria | 8 mode | DIN rail mounting | Size: 8 DIN modules | |
| | Input function | Generates alarm or Generates fault | Model TFM50-HP Dimensions (L x H x D) and weight | 144 x 118 x 71,5mm 300g | |
| | Generates evacuation alarm | Programmable | Model TFM50-LP Dimensions (L x H x D) and weight | 144 x 118 x 38,5mm 260g | |
| Loop interface | Addressing | 1 rotary switch and 1 DIP switch | Conformity | Standards | EN 54-18:2005/AC:2007 EN 54-17:2005 |
| | Occupied addresses | Max. 5 (1 per unit) | | System compatibility | EN 54-13:2020 |
| | Communication protocol | FIRE-SPEED | | Certification number | 1293-CPR-0527 |
| | Loop isolator | Double insulator | | Year of CE marking | 16 |
| Specifications Inputs / Outputs | Input current consumption in alarm | 2.3mA @ 24V DC | | Number of declaration of performance | 018_TFM50 |
| | Output for optical repeater | 9.V DC 3mA | | Notified body | EVPU |
| Electrical specifications | Nominal voltage | 24V DC | | | |
| | Operating voltage | 18V...30V DC | | | |
| | Consumption | 500µA @ 24V DC | | | |

N.B. Declarations of conformity and performance are available on www.tecnofire.com



EVPU
Tested



Tecnofire
DETECTION
by Tecnofire S.r.l. - Via Ciriè 38 - 10099 - San Mauro T.se - Torino (Italy)
Manufacturing plant: Strada del Cascinotto 139/54 - 10156 - Torino (Italy) - www.tecnofire.com

The product features can be subject to change without notice.